

**GLAZING - ARMRSIELD - ARM - Non-Fire-Rated Ballistics Glazing**

A lightweight option that offers three levels of ballistic protection. This glazing is designed for the high demands of ballistic and forced entry glazing applications.

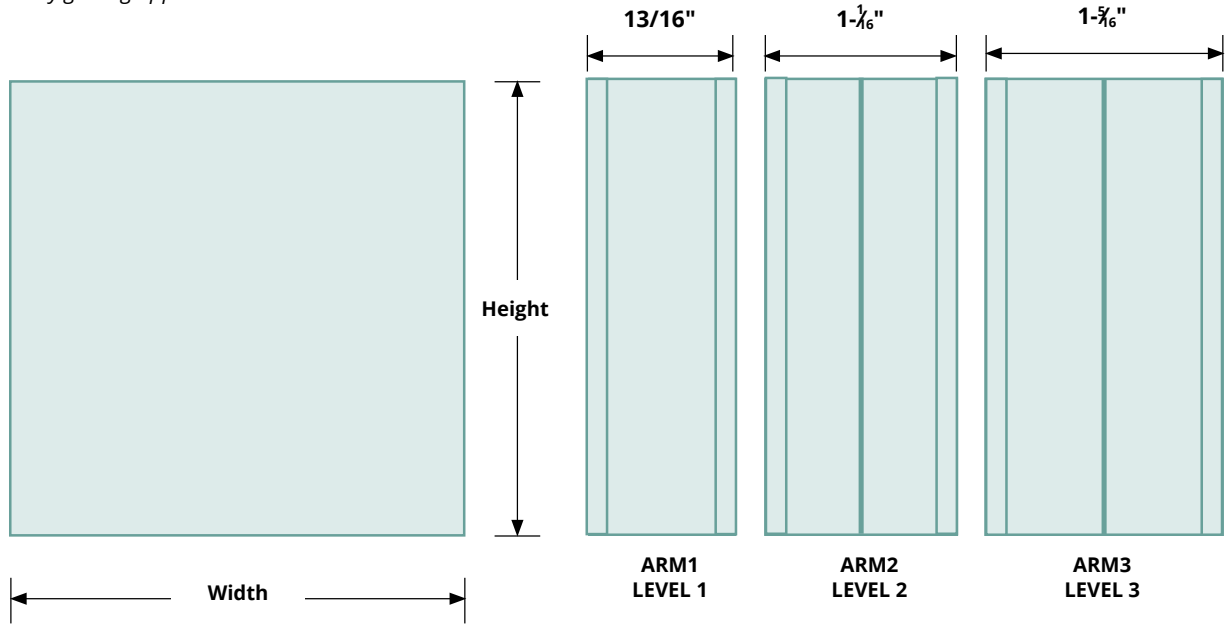

**MADE-TO-ORDER ARMRSIELD GLASS - EXAMPLE: ARM1 1111-1316**

QTY	MODEL	LEVEL	WIDTH	HEIGHT	THICKNESS	TAPE APPLIED OPTIONS
	ARM	1			1316 13/16" Level 1	None
		2			01116 1-1/16" Level 2	T Standard Tape 1/16"
		3			01516 1-5/16" Level 3	

DISCLAIMER: The manner in which you use and the purpose to which you put and utilize our products, technical assistance and information (whether verbal, written or by way of production evaluations), including any suggested formulations and recommendations are beyond our control. Therefore, it is imperative that you test our products, technical assistance and information to determine to your own satisfaction whether our products, technical assistance and information are suitable for your intended uses and applications. This application-specific analysis must at least include testing to determine suitability from a technical as well as health, safety, and environmental standpoint. Such testing has not necessarily been done by us. Unless we otherwise agree in writing, all products are sold strictly pursuant to the terms of our standard conditions of sale which are available upon request. All information and technical assistance is given without warranty or guarantee and is subject to change without notice. It is expressly understood and agreed that you assume and hereby expressly release us from all liability, in tort, contract or otherwise, incurred in connection with the use of our products, technical assistance, and information. Any statement or recommendation not contained herein is unauthorized and shall not bind us. Nothing herein shall be construed as a recommendation to use any product in conflict with any claim of any patent relative to any material or its use. No license is implied or in fact granted under the claims of any patent. Please consult your AHJ to make sure your glazing complies with local ordinances before ordering.

**SPECIFICATIONS:**

- Material:** 3 or 4 ply polycarbonate laminate
- Thickness:** 13/16", 1-1/16", 1-5/16" (20.6, 26.5, 33 mm)
- Weight:** 5.1, 6.5, 8.1 psf
- Light Transmission:** 88%, 72%, 72%
- STC:** 35, 36, 37
- Size:**

- ARM1:** Minimum 4" x 4", Maximum: 48" x 96"
  - ARM2:** Minimum 4" x 4", Maximum: 60" x 96"
  - ARM3:** Minimum 4" x 4", Maximum: 48" x 96"
- Order size is actual glass size

**RATINGS:**

- Glazing bug marking on lower right corner
- ARM1 UL 752 Level 1:** 9 mm full metal jacket with lead core
- ARM2 UL 752 Level 2:** .357 Magnum lead jacketed soft point, ASTM F 1233.08 Class 5 & 2.5, ASTM F 1915.03 Grade 1, HP White TP 0500.03 Level IV Sequence 43
- ARM3 UL 752 Level 3:** .44 Magnum lead semi-wadcutter/gas checked, ASTM F 1233.08 Class 5 & 2.5, ASTM F 1915.03 Grade 1, HPW TP 0500.03 Level IV, Sequence 43-44
- Impact Safety Rating:** CPSC 16CFR 1201 (CAT I & II)

**Warranty:** Seven year limited

**Compatible Frames:** Not tested to UL 752

- ARM1:** VLFIG, EZline, VLFEZIG, Slimline VSIG, VLFS10
- ARM2:** Thrubolt VLFIG
- ARM3:** Thrubolt VLFIG

**OPTIONS & ACCESSORIES:**

**Tape:** Standard glazing tape applied to both sides of glazing

**NOTE:** This is not a fire-rated product and should not be used in fire-rated door applications.

Please consult with your AHJ to make sure your glazing complies with local ordinances before ordering.

**TAPE WHEN SOLD SEPARATELY**

Qty	Model	Description / Dimensions
	GTAPE 200B	Standard glazing tape 1/16" thick x 3/8" wide x 200 ft

Refer to glazing tape submittal for more information

It is the responsibility of the customer to communicate specifications and product performance requirements that are needed for their application. This document is intended to convey potential product configurations and offerings. It is not to be used to imply or represent a specification or rating of finished products shipped. Detailed, specific submittals can be created upon request. It is the responsibility of the customer to specify product accordingly to comply with local laws, codes, and ordinances.

 <p><b>AIR LOUVERS</b> 9702 Newton Ave S. Bloomington, MN 55431   Many Locations Nationwide</p>	<p>800-554-6077 sales@activarcpg.com www.activarcpg.com</p>	<p><b>Distributor:</b></p>	<p><b>Project:</b></p>
		<p><b>Contractor:</b></p>	<p><b>Approved By:</b></p>
		<p><b>Date:</b></p>	<p><b>Architect:</b></p>
		<p><b>Scale: N/A</b></p>	<p><b>Pages: 1 of 1</b></p>